



IN THE EVENT THAT FIXTURE LOCATIONS NEED TO CHANGE, PLEASE CHECK WITH SKYTRON ON THE REVISED LAYOUT LOCATION. FINAL CONSTRUCTION DOCUMENTS SHOULD BE PROVIDED BY THE ARCHITECT.



GENERIC LAYOUT

EQUIPMENT SCHEDULE	
ID	DESCRIPTION
A	ANESTHESIA / MONITOR
B	LIGHTS & MONITOR W/ EQUIPMENT
* IF SKYVISION IS APPLICABLE REFER TO THE LAST PORTION OF BOOM PACKAGE*	

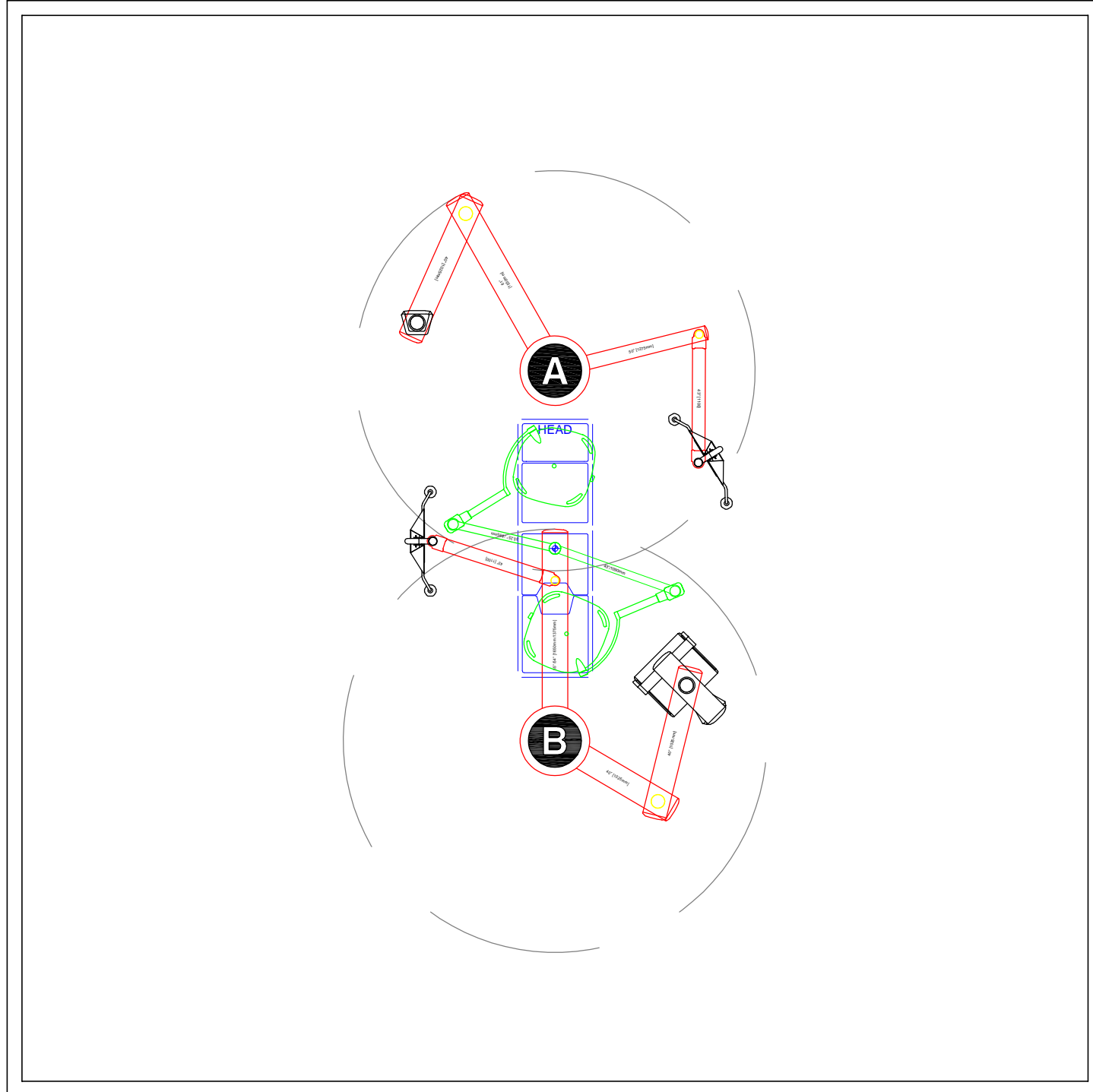

INITIAL: _____
DATE: _____

PROJECT #: 21-000
PRELIMINARY
PLOT DATE: 9/9/2021

ROBOTIC OR

ROOM TYPE: ROBOTIC OR
REV #: 0
DESCRIPTION: ROOM LAYOUT

SHEET
00

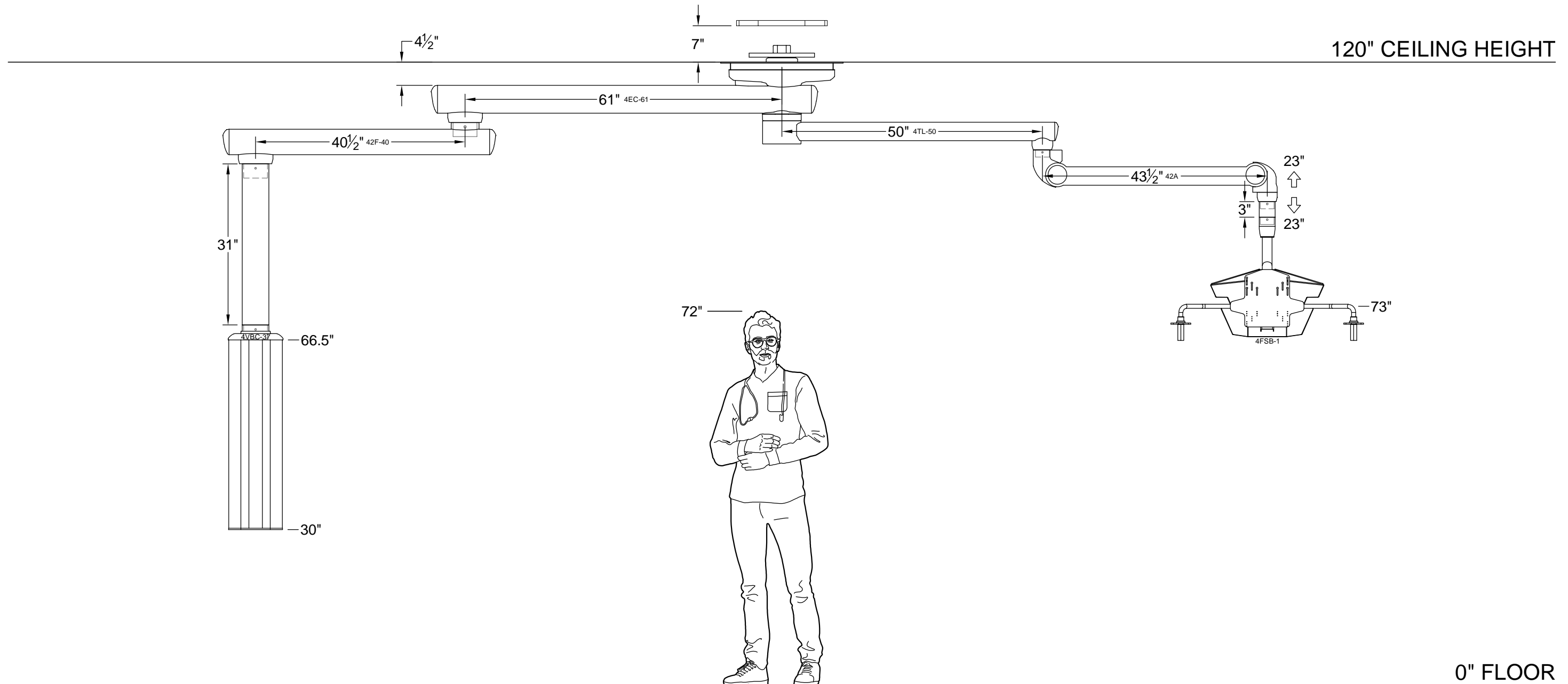

ROBOTIC OR

INITIAL: _____
DATE: _____

Max Fixture Weight: 1,188 lbs.
Max Moment Load: 6,922 ft. lbs.

Equipment Capacity: 4VBC-37 - 368 lbs.
4FSB-1 - 40 lbs.

REF #: C-70906-1
MODEL: F320 SERIES
DESCRIPTION: ELEVATION DETAILS

QTY: 1
REV #: 0

SHEET
A1

Note:
Communications can only
be placed above the
top-most separator plate

FRONT-LEFT VIEW

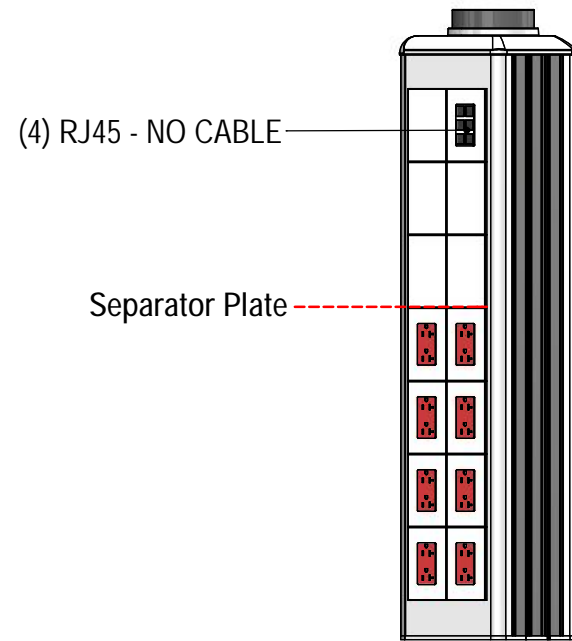

FRONT-RIGHT VIEW

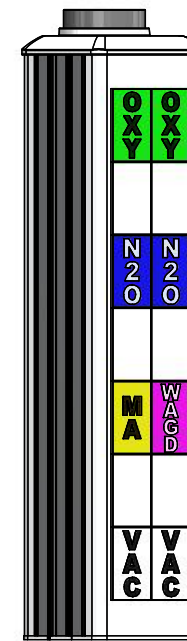

DESCRIPTION	QTY.
OXYGEN	2
NITROUS OXIDE	2
MEDICAL AIR	1
WAGD	1
VACUUM	2

ELECTRICAL OUTLETS: (8) 125V, 20A DUPLEX - RED

GAS FACEPLATE STYLE: DISS

CARRIER DIMENSIONS: 37.75"H x 10.75"W x 8.25"D

GAS COLOR KEY:

CARBON DIOXIDE	MEDICAL AIR	OXYGEN
HELIOX	NITROGEN	VACUUM
INSTRUMENT AIR	NITROUS OXIDE	WAGD

FOR A COMPLETE LIST OF ACCESSORIES
REFER TO YOUR QUOTE

INITIAL: _____
DATE: _____

PROJECT #: 21-100
PRELIMINARY
PLOT DATE: 9/9/2021

ROBOTIC OR

QTY: 1
REV #: 0
REF #: C-70906
MODEL: F320 SERIES
DESCRIPTION: CARRIER DETAILS

SHEET
A2

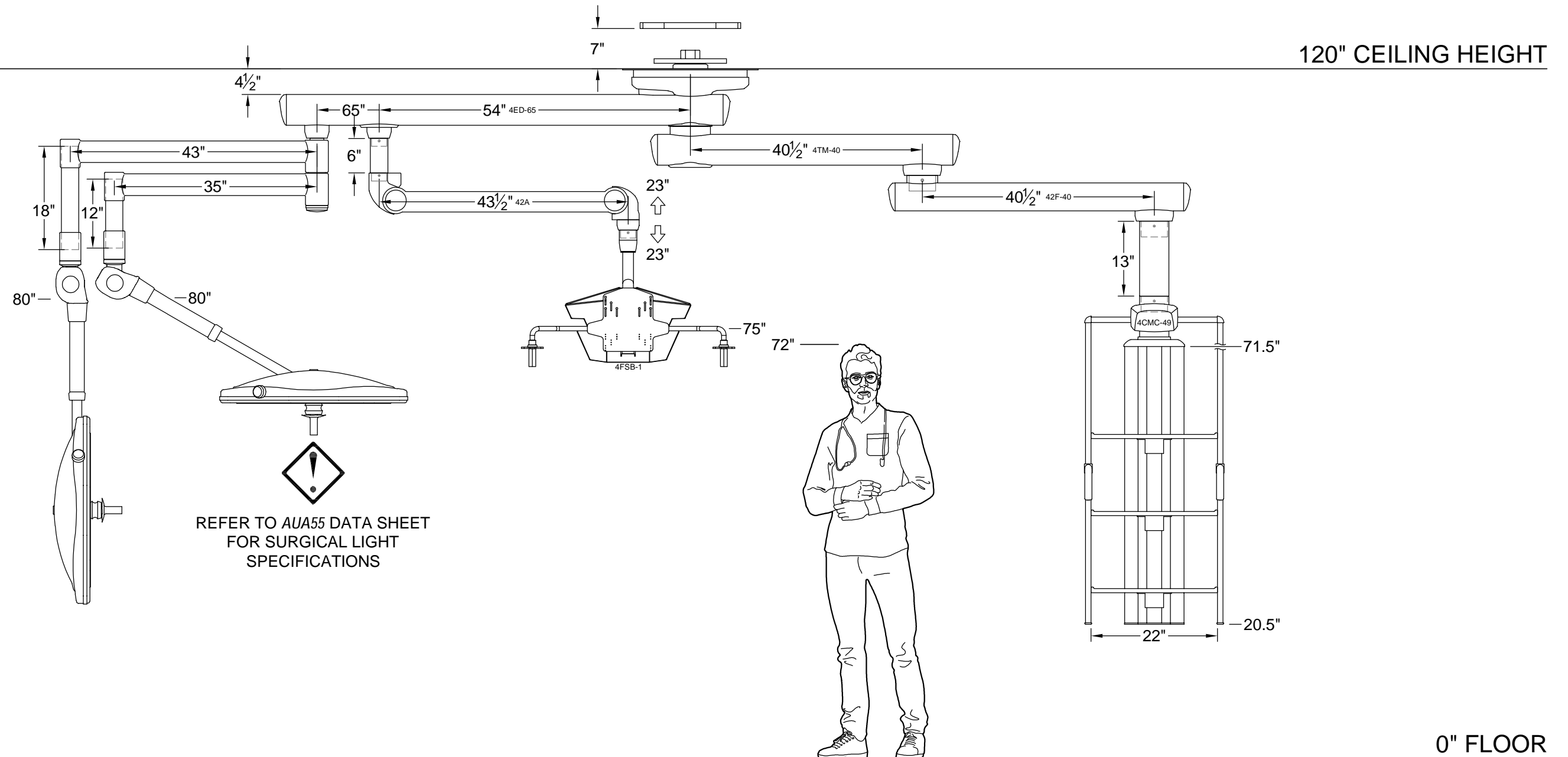

ROBOTIC OR

QTY: 1
REV #: 0

REF #: C-70911
MODEL: F440 SERIES
DESCRIPTION: ELEVATION DETAILS

SHEET

B1

INITIAL: _____
DATE: _____

Max Fixture Weight: 1,574 lbs.
Max Moment Load: 8,334 ft. lbs.

Equipment Capacity: 4FSB-1 - 41 lbs.
4CMC-49 - 271 lbs.

Note:
Communications can only
be placed above the
top-most separator plate

FRONT-LEFT VIEW

FRONT-RIGHT VIEW

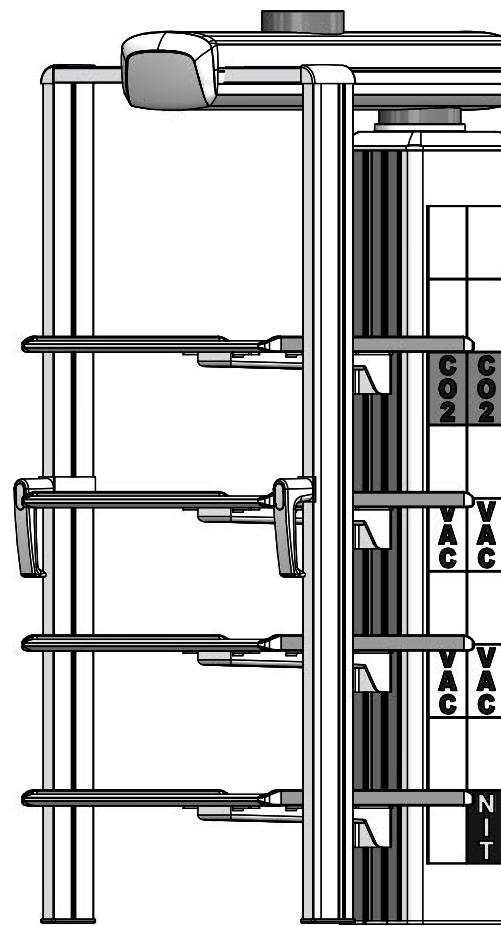
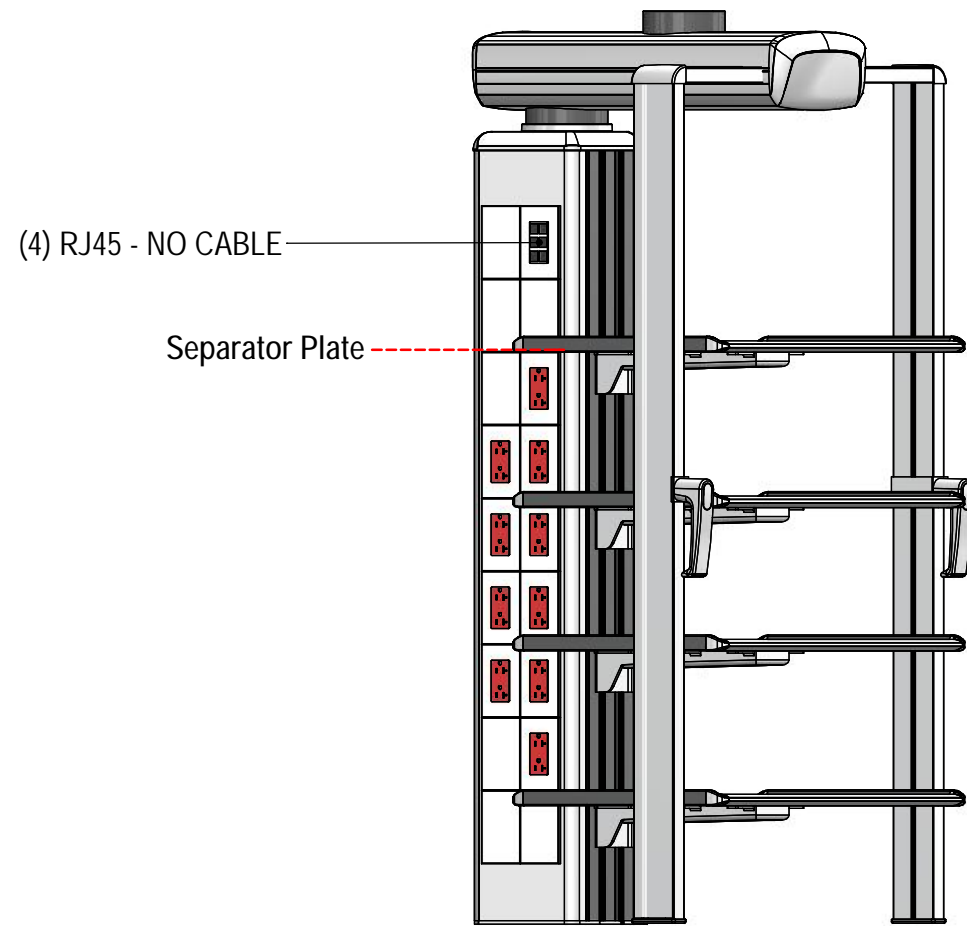

ELECTRICAL OUTLETS: (10) 125V, 20A DUPLEX - RED

GAS FACEPLATE STYLE: DISS

CARRIER DIMENSIONS: 56"H x 24"W x 28.75"D

GAS COLOR KEY:

CARBON DIOXIDE	MEDICAL AIR	OXYGEN
HELIOX	NITROGEN	VACUUM
INSTRUMENT AIR	NITROUS OXIDE	WAGD

DESCRIPTION	QTY.
CARBON DIOXIDE (DISS)	2
VACUUM	4
NITROGEN (DISS)	1

INITIAL: _____
DATE: _____

FOR A COMPLETE LIST OF ACCESSORIES
REFER TO YOUR QUOTE

PROJECT #: 21-100
PRELIMINARY
PLOT DATE: 9/9/2021

ROBOTIC OR

QTY: 1
REV #: 0
REF #: C-70911
MODEL: F440 SERIES
DESCRIPTION: CARRIER DETAILS

SHEET
B2