



IN THE EVENT THAT FIXTURE LOCATIONS NEED TO CHANGE, PLEASE CHECK WITH SKYTRON ON THE REVISED LAYOUT LOCATION. FINAL CONSTRUCTION DOCUMENTS SHOULD BE PROVIDED BY THE ARCHITECT. DIMENSIONS PROVIDED FROM WALLS ARE BASED ON CURRENT INFORMATION PROVIDED TO SKYTRON AT TIME OF DOCUMENT CREATION.



SITE SPECIFIC LAYOUT

| EQUIPMENT SCHEDULE | |
|---|-------------------------------|
| ID | DESCRIPTION |
| A | ANESTHESIA |
| B | RAD SHIELD W/ LIGHT |
| C | MONITOR / RAD SHIELD W/ LIGHT |
| D | LARGE DISPLAY / EQUIPMENT |
| | |
| | |
| | |
| * IF SKYVISION IS APPLICABLE REFER TO THE LAST PORTION OF BOOM PACKAGE* | |

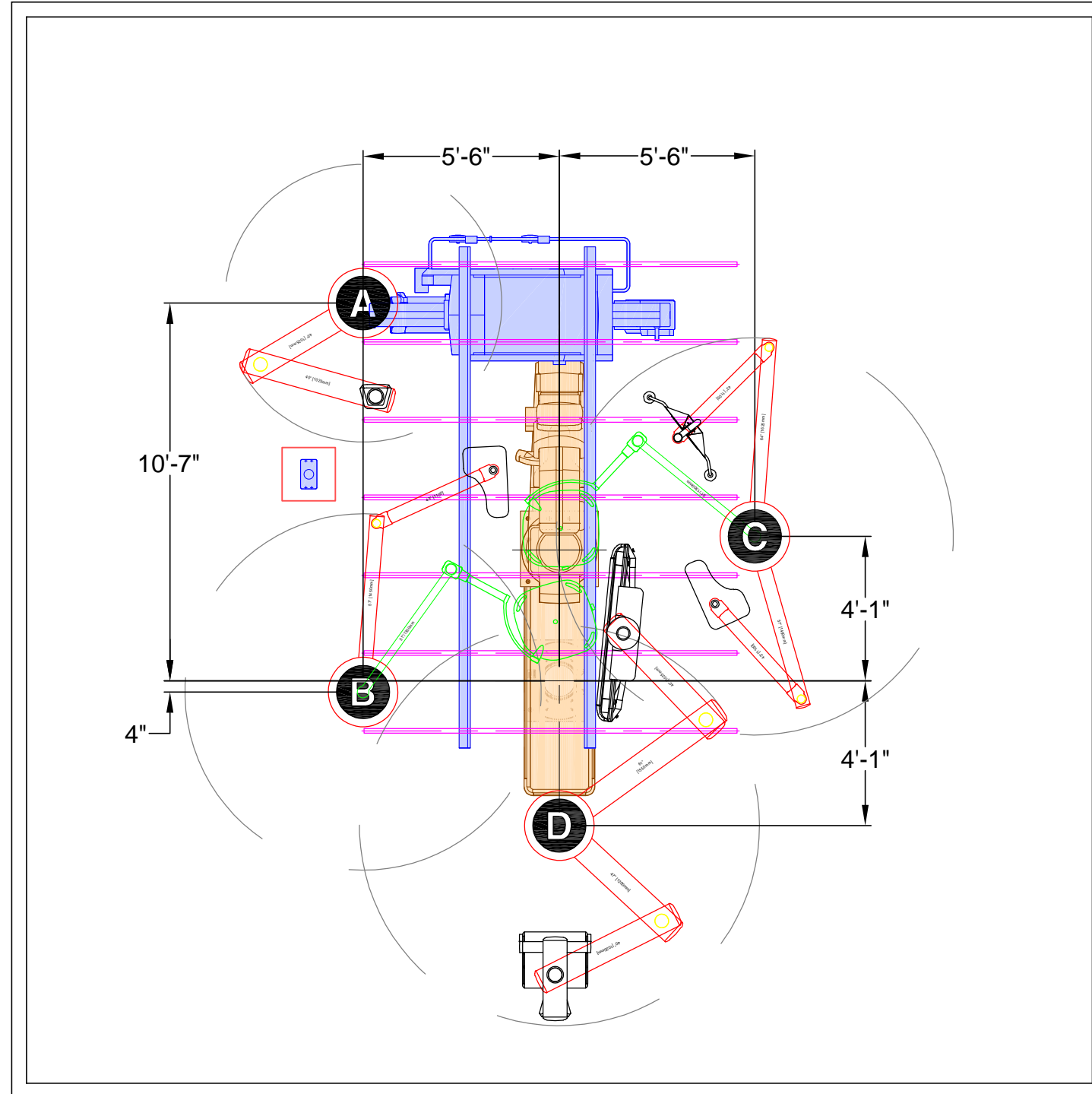

INITIAL: _____
DATE: _____

PROJECT #: 21-000
PRELIMINARY
PLOT DATE: 9/10/2021

ROOM TYPE: PHILIPS BIPLANE
DESCRIPTION: ROOM LAYOUT

REV #: 0

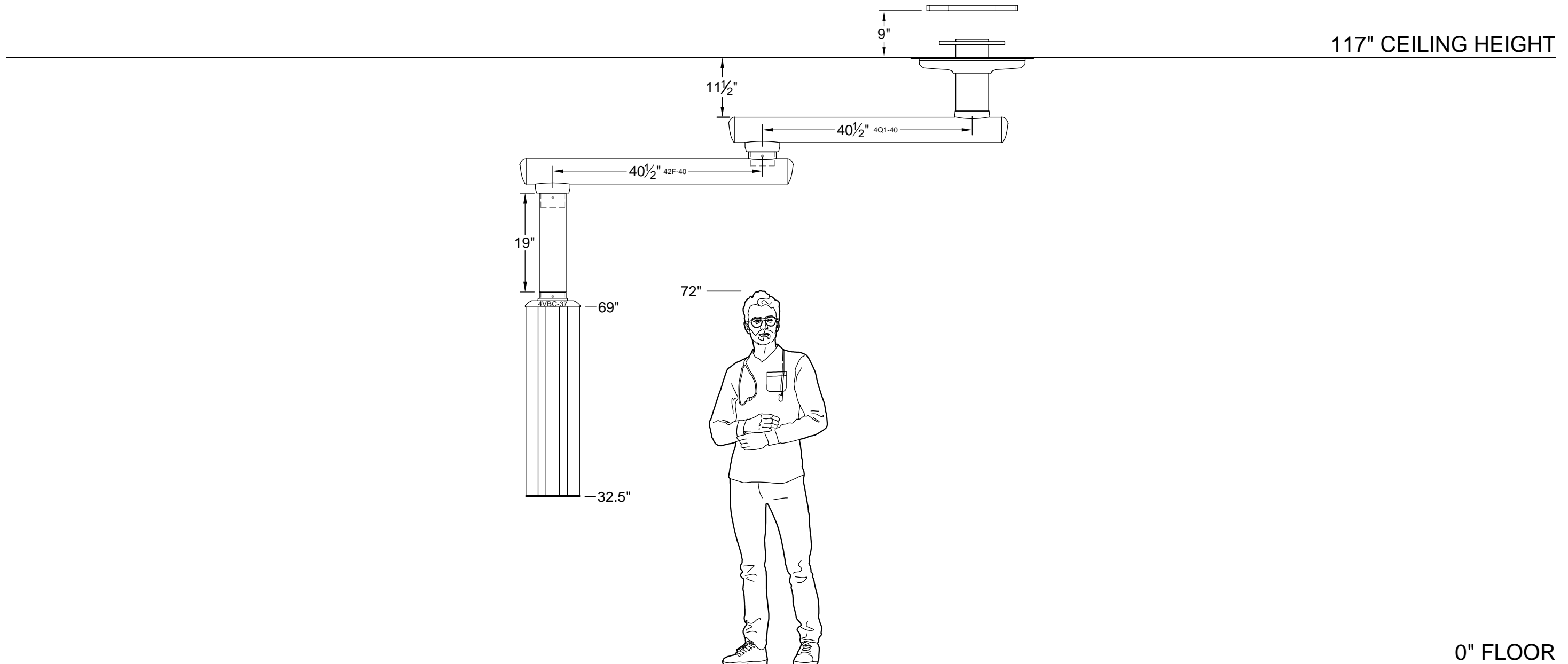

HYBRID 3 - PHILIPS BIPLANE

QTY: 1
REV #: 0
MODEL: F200 SERIES
DESCRIPTION: ELEVATION DETAILS

REF #: C-75496

INITIAL: _____
DATE: _____

Max Fixture Weight: 538 lbs.
Max Moment Load: 2,581 ft. lbs.

Equipment Capacity: 4VBC-37 - 244 lbs.

Note:
Communications can only
be placed above the
top-most separator plate

FRONT-LEFT VIEW

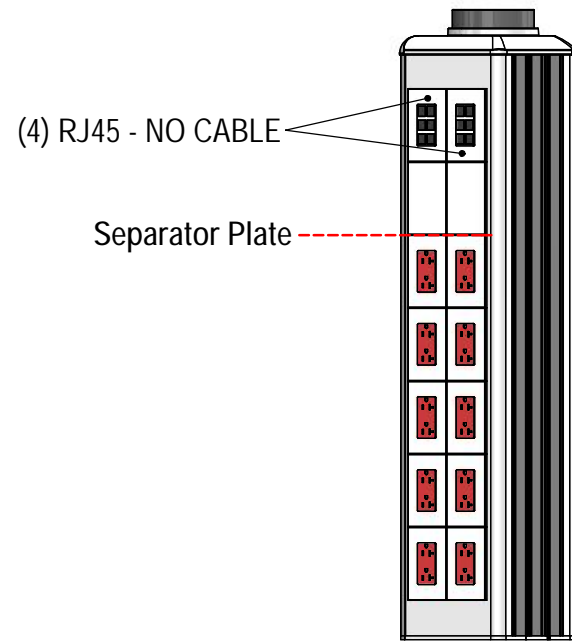

FRONT-RIGHT VIEW

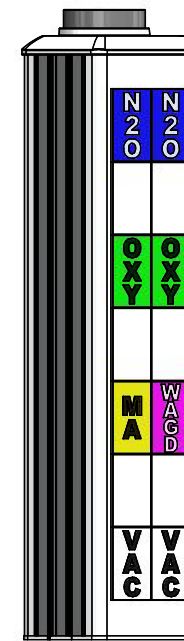

| DESCRIPTION | QTY. |
|---------------|------|
| OXYGEN | 2 |
| NITROUS OXIDE | 2 |
| MEDICAL AIR | 1 |
| WAGD | 1 |
| VACUUM | 2 |

ELECTRICAL OUTLETS: (10) 125V, 20A DUPLEX - RED

GAS FACEPLATE STYLE: DISS

CARRIER DIMENSIONS: 37.75"H x 10.75"W x 8.25"D

GAS COLOR KEY:

| | | |
|----------------|---------------|--------|
| CARBON DIOXIDE | MEDICAL AIR | OXYGEN |
| HELIOX | NITROGEN | VACUUM |
| INSTRUMENT AIR | NITROUS OXIDE | WAGD |

FOR A COMPLETE LIST OF ACCESSORIES
REFER TO YOUR QUOTE

INITIAL: _____
DATE: _____

PROJECT #: 21-000
PRELIMINARY
PLOT DATE: 9/10/2021

HYBRID 3 - PHILIPS BIPLANE

QTY: 1
REV #: 0
REF #: C-75496
MODEL: F200 SERIES
DESCRIPTION: CARRIER DETAILS

SHEET
A2

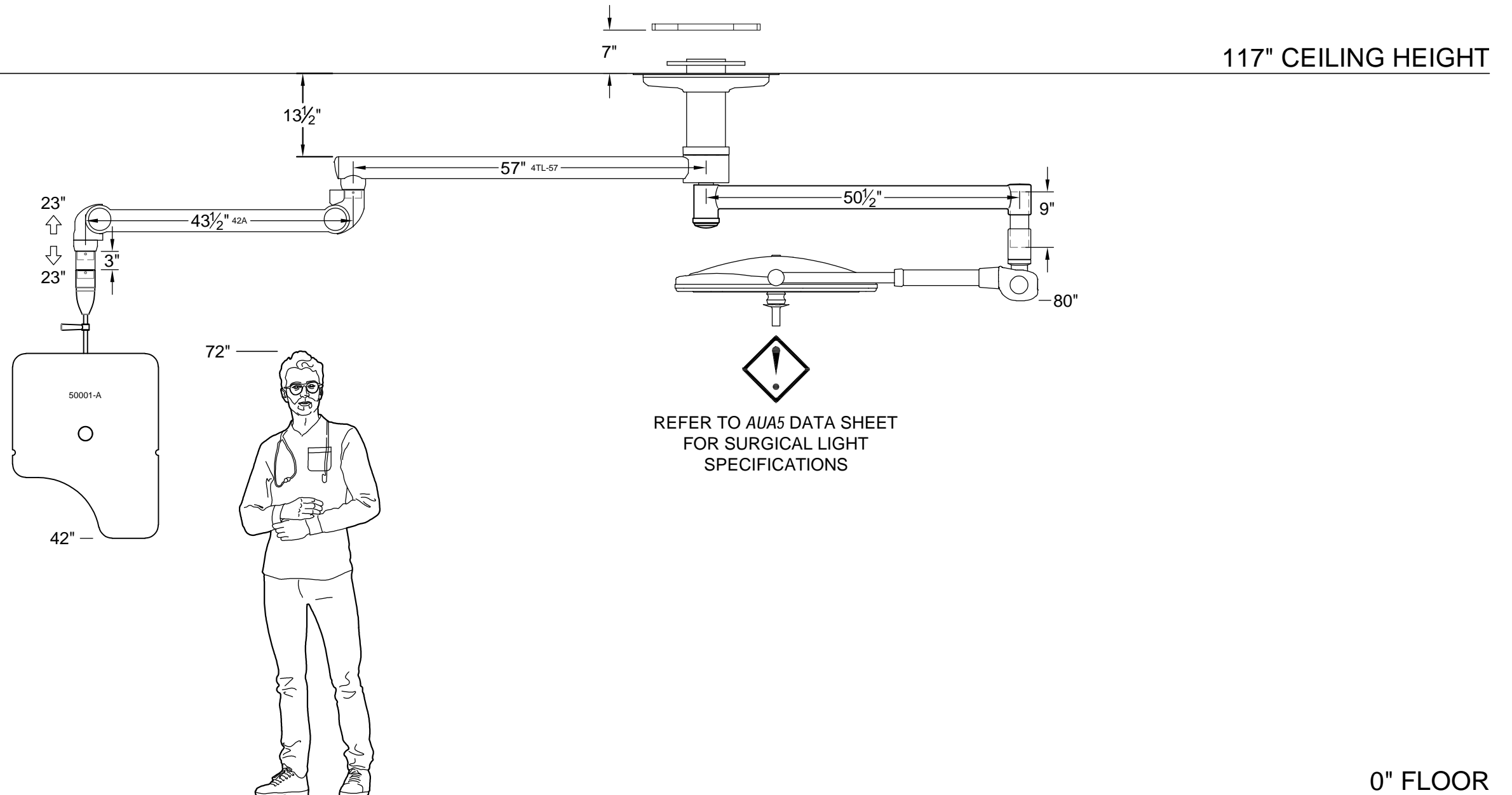

HYBRID 3 - PHILIPS BIPLANE

QTY: 1
REV #: 0
MODEL: F110 SERIES
DESCRIPTION: ELEVATION DETAILS

REF #: C-75500

SHEET

B1

INITIAL: _____
DATE: _____

Max Fixture Weight: 487 lbs.
Max Moment Load: 2,570 ft. lbs.

Equipment Capacity: X-RAY 50001-A - 6 lbs.

HYBRID 3 - PHILIPS BIPLANE

REF #: C-75504
MODEL: F120 SERIES
DESCRIPTION: ELEVATION DETAILS

QTY: 1
REV #: 0
SHEET
C1

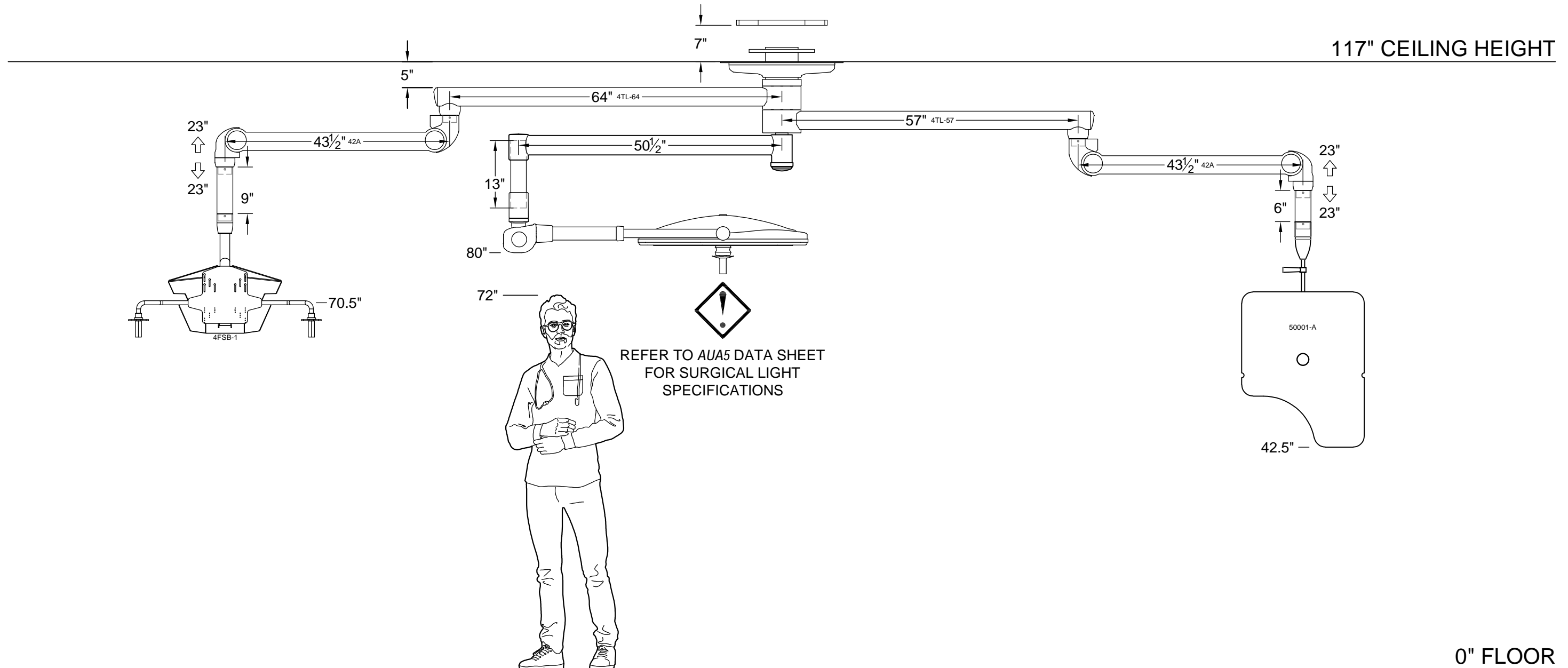

Max Fixture Weight: 723 lbs.
Max Moment Load: 3,953 ft. lbs.

Equipment Capacity: 4FSB-1 - 38 lbs.
X-RAY 50001-A - 4 lbs.

INITIAL: _____
DATE: _____

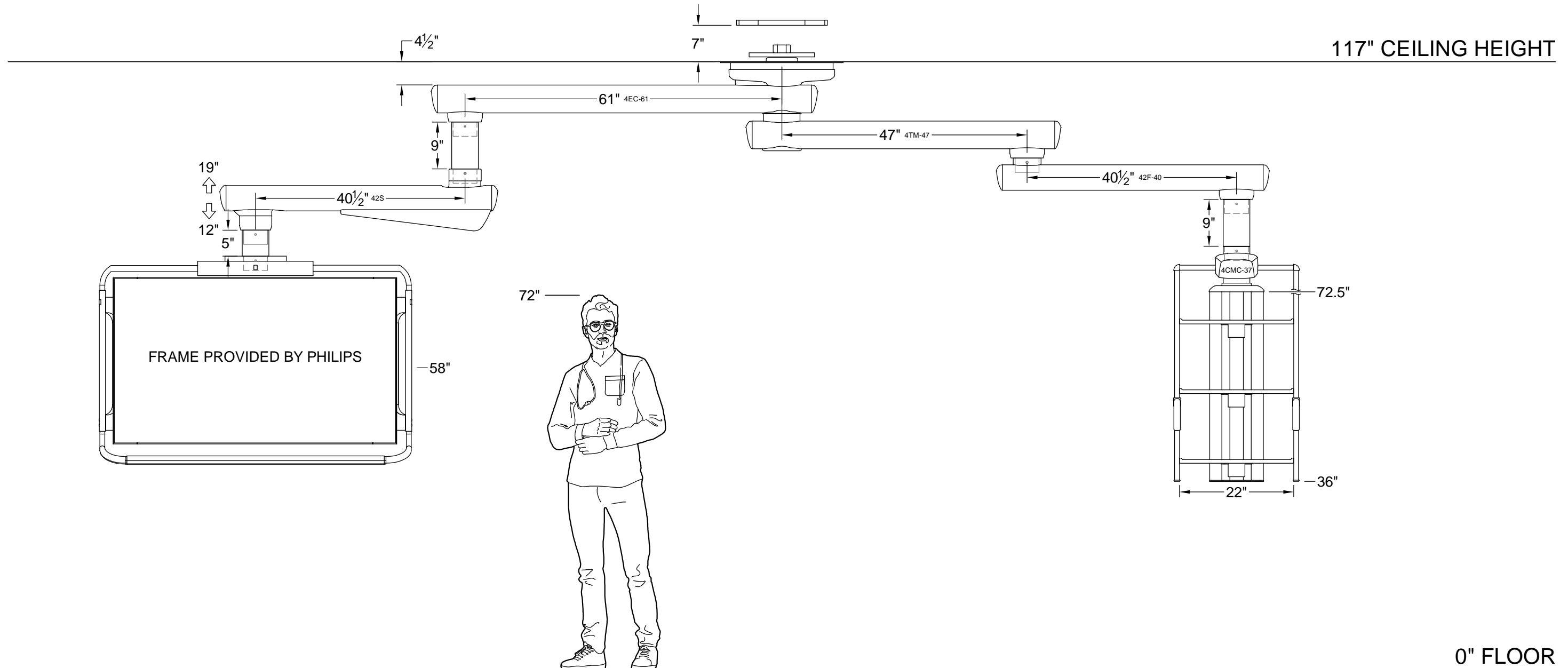

HYBRID 3 - PHILIPS BIPLANE

QTY: 1
REV #: 0
MODEL: F340 SERIES
DESCRIPTION: ELEVATION DETAILS

REF #: C-75509

SHEET

D1

INITIAL: _____
DATE: _____

Max Fixture Weight: 1,673 lbs.
Max Moment Load: 8,829 ft. lbs.

Equipment Capacity: 4MCS-PHILIPS - n/a
4CMC-37 - 245 lbs.

Note:
Communications can only
be placed above the
top-most separator plate

FRONT-LEFT VIEW

FRONT-RIGHT VIEW

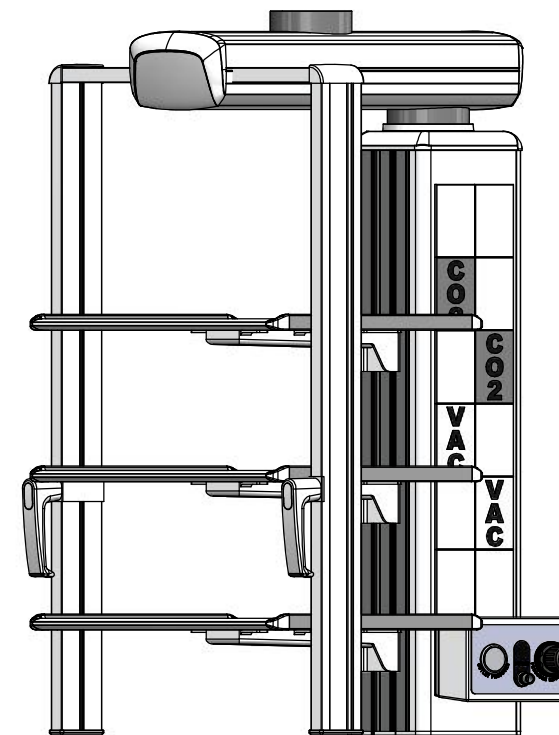
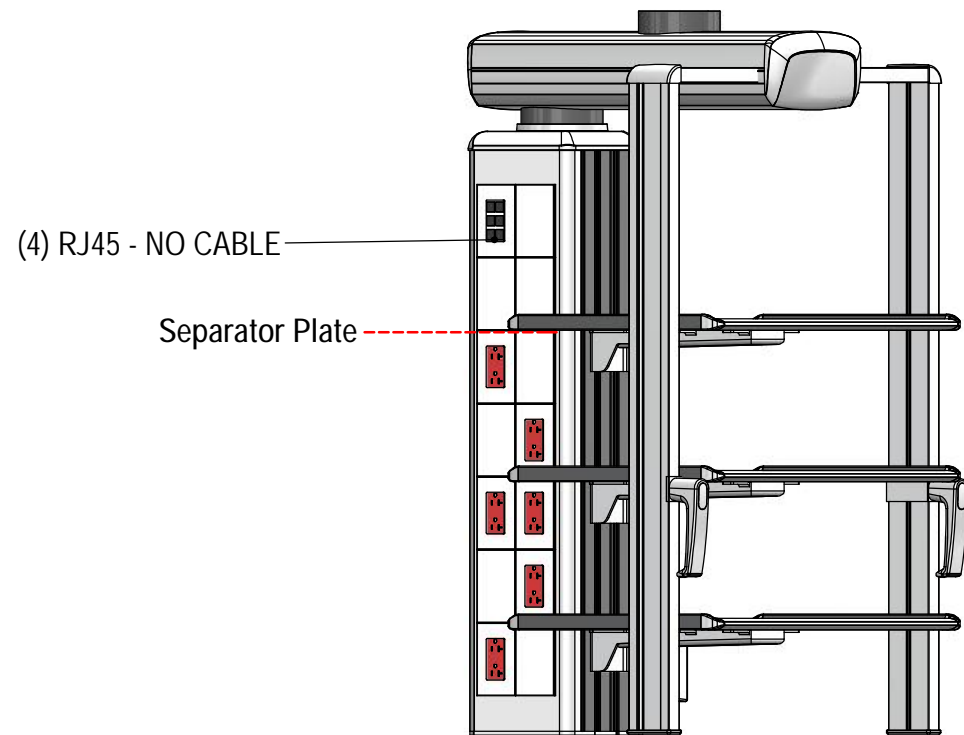

ELECTRICAL OUTLETS: (6) 125V, 20A DUPLEX - RED

GAS FACEPLATE STYLE: DISS

CARRIER DIMENSIONS: 44"H x 24"W x 28.75"D

GAS COLOR KEY:

| | | |
|----------------|---------------|--------|
| CARBON DIOXIDE | MEDICAL AIR | OXYGEN |
| HELIOX | NITROGEN | VACUUM |
| INSTRUMENT AIR | NITROUS OXIDE | WAGD |

| DESCRIPTION | QTY. |
|------------------------|------|
| CARBON DIOXIDE (DISS) | 2 |
| VACUUM | 2 |
| SINGLE NITROGEN SYSTEM | 1 |

INITIAL: _____
DATE: _____

FOR A COMPLETE LIST OF ACCESSORIES
REFER TO YOUR QUOTE

PROJECT #: 21-000
PRELIMINARY
PLOT DATE: 9/10/2021

HYBRID 3 - PHILIPS BIPLANE

REF #: C-75509
MODEL: F340 SERIES
DESCRIPTION: CARRIER DETAILS

QTY: 1
REV #: 0
SHEET
D2