

DARELO



LED
Volumetric
Troffer



Features

- Lumen maintenance.
- High-quality LED Chips to provide high efficiency
- Polycarbonate lens (option), high flame retardant point.
- Exceptional efficacy meets DLC Premium requirements.
- Pure aluminum heat sinks offers heat transmission faster than die-cast steel.
- Damp Location Rated

LED Volumetric Troffer

Our High-Performance 2x4 and 2x4 Center Troffer lights provide high energy-saving LED diffuse light for use in private offices, open office areas, upscale retail applications, public circulation areas, and classrooms.

The newest LED troffers can deliver significant savings.

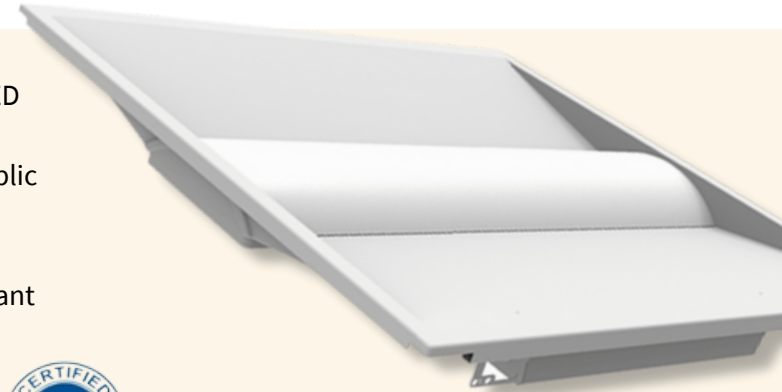

Commonly Used



Office



School



Hospital

Specifications

ITEM	ITEM NO.	POWER	VOLTS	LIFETIME	Length (IN)	WIDTH (IN)	HEIGHT (IN)
LED LVT/25W/23	DA-5415	25W	120-277V	50,000hrs+	23.82	23.82	3.15
LED LVT/40W/23	DA-5416	40W	120-277V	50,000hrs+	23.82	23.82	3.15
LED LVT/40W/47	DA-5417	40W	120-277V	50,000hrs+	47.64	23.82	3.15
LED LVT/50W/47	DA-5418	50W	120-277	50,000hrs+	47.64	23.82	3.15

Photometric

ITEM	ITEM NO.	CCT	LUMEN	EFFICACY	BEAM ANGLE	CRI
LED LVT/25W/23	DA-5415	35K,40K,50K	2,500LM-3,000LM	100lm/w~120lm/w	H124.7 V108.7	>82
LED LVT/40W/23	DA-5416	35K,40K,50K	4,000LM-4,800LM	100lm/w~120lm/w	H124.7 V108.7	>82
LED LVT/40W/47	DA-5417	35K,40K,50K	4,000LM-4,800LM	100lm/w~120lm/w	H124.7 V108.7	>82
LED LVT/50W/47	DA-5418	35K,40K,50K	5,000LM-6,000LM	100lm/w~120lm/w	H124.7 V108.7	>82

Ordering

ITEM NO.	LENS COLOR	POWER	LENGTH	MOUNTING	CCT	DRIVER	ACCESSORIES
LED LVT	LM-Milky lens	25W	2X2ft.	B:Recessed/Surface	30:3000K	D1-120-277V	A: No Sensor & EM
	LD- Clear lens	40W	2x4ft.		35:3500K	D2-347V	B: With Sensor
		50W			40:4000K	D3-120-347V	C: With EM
					45:4500K	D4-120-277V wattage selectable	D: With Sensor&EM
					50:5000K	D5-120-347V wattage selectable	
					VK-CCT tunable	D6-347-480V	

Installation Guide

2ft:

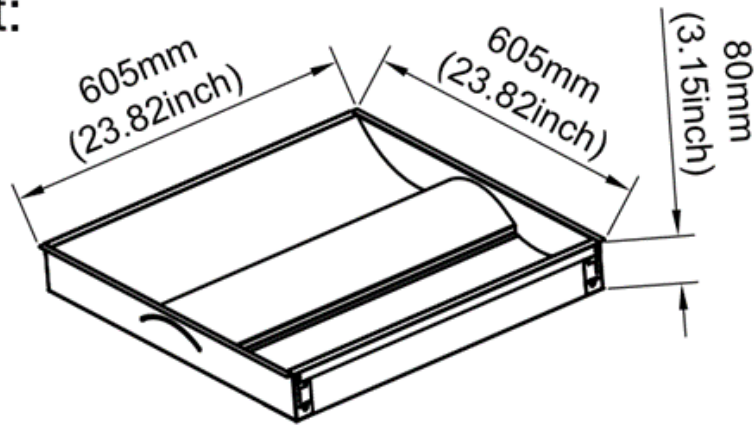

4ft:

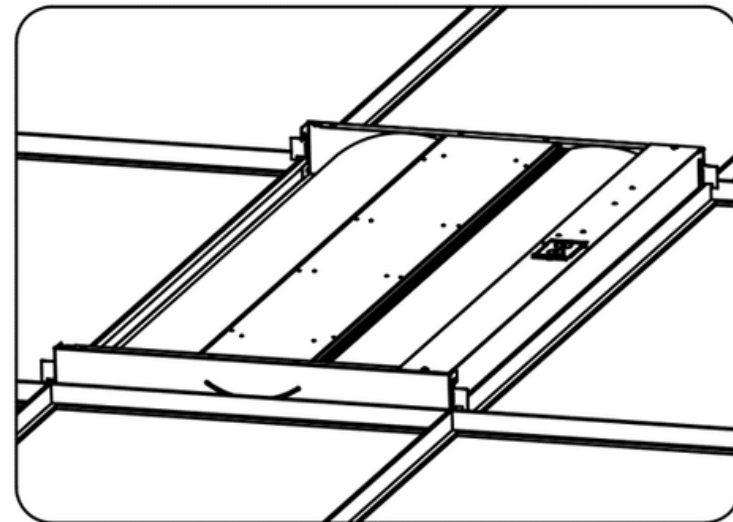
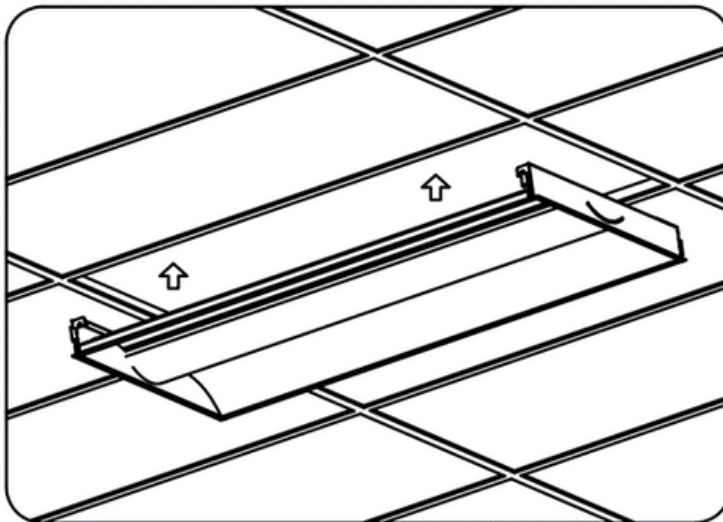
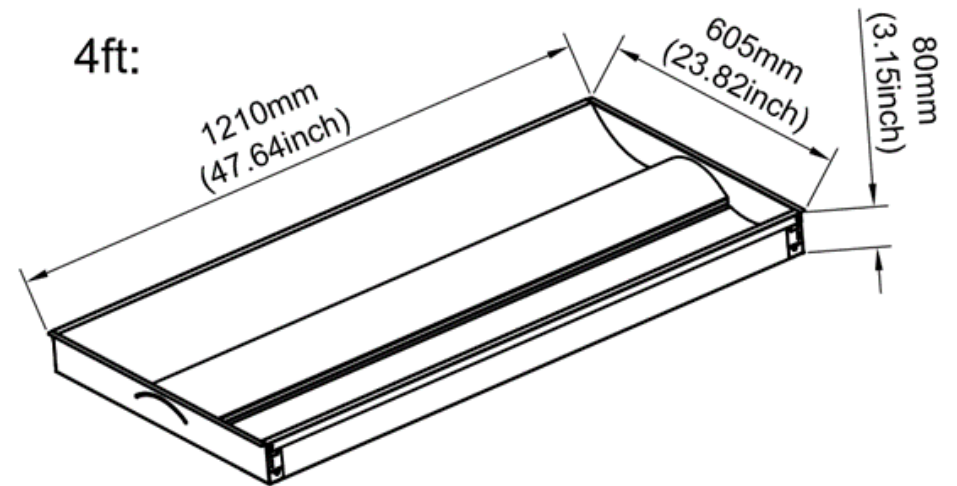

■ Accessories To Be Added Separated

1. Sensor & Emergency it | ■ DA-5419

Internal
Microwave
Motion Sensor



90mins 8W
Emergency battery



2. Surface Mounted | ■ DA-5420

Surface Mounted
Frame

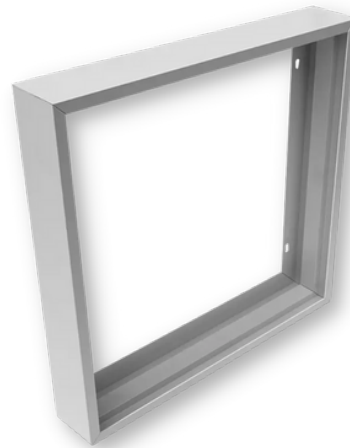

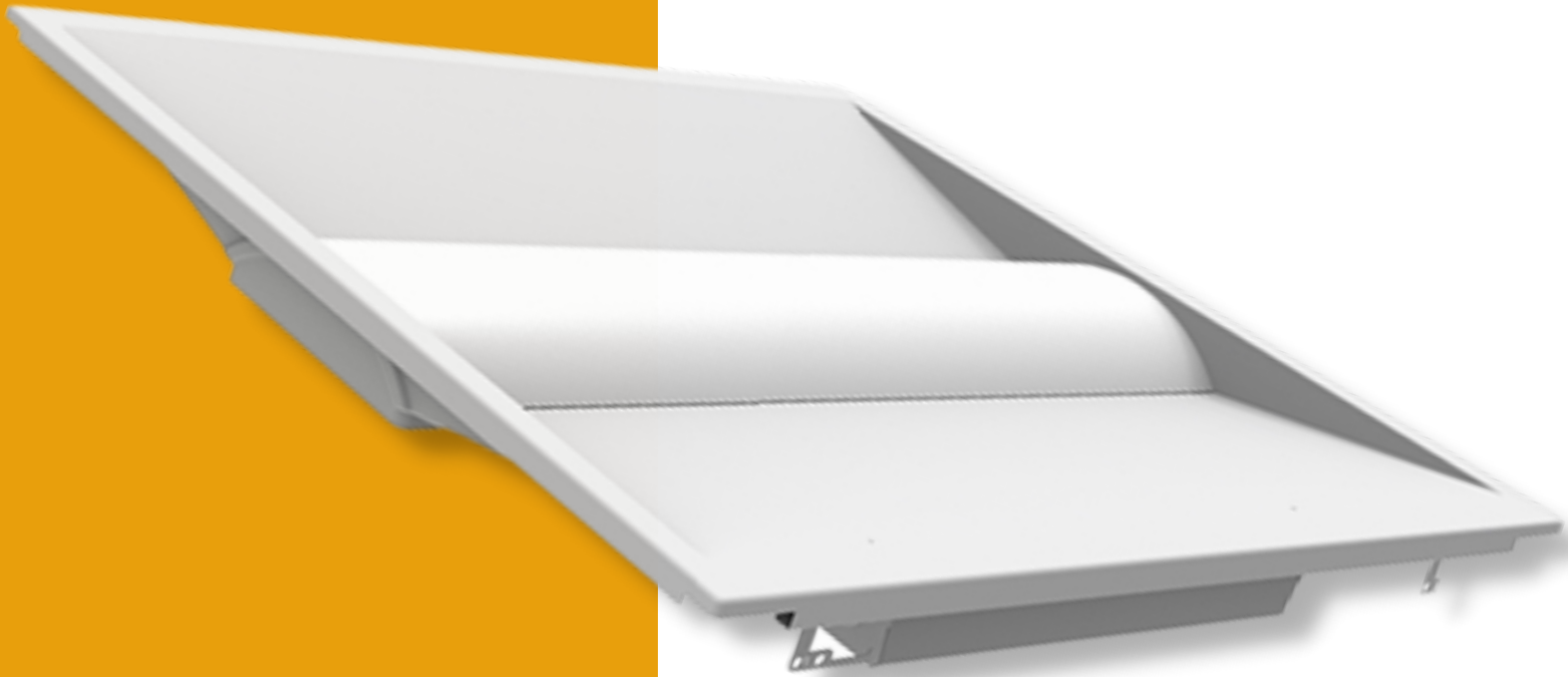

■ **COMFORTABILITY**

No flicker. No glare.



- **NATURAL LIGHT**

Our LED Troffer is softer and more uniform.

DARELO

We Make It Easy to Choose

Contact Info

Email : sales@darelo.com

Tel No : 845-241-8536

Website : www.darelo.com