



# NEW MEXICO STEAM LOCOMOTIVE & RAILROAD HISTORICAL SOCIETY

MAILING ADDRESS  
P.O. Box 27270  
Albuquerque, NM 87125-7270  
Restoration Site: 1833 8th St. NW, Albuquerque  
Web Site: [www.nmslrhs.org](http://www.nmslrhs.org) Email: [nmslrhs@nmslrhs.org](mailto:nmslrhs@nmslrhs.org)



Vol. XII, No. 4 Tel. 505 246-2926 Oct--Nov--Dec.2013

## PHOTO SHOOT AT 2926

### Nikon Professional Services Team Photographs An Icon Of The Steam Era

Lots of photographers, amateur and professional, visit 2926 to get photos of the locomotive restoration. They usually show up individually, or at the most two or three at a time. Many amateurs just want get a picture of their youngsters next to the locomotive, or their grandfather or uncle standing next to the machine he once worked on. Our mid-November visitors were a bit different.

So, how did we respond when 16 world class photographers showed up at the gate to take pictures of 2926?

We don't know how others would respond, but the 2926 crew welcomed them in, gave them hard hats, and allowed them full access to the restoration site. Bill Pekala, General Manager of Nikon Professional Services (NPS), and fifteen members of his NPS team came loaded with a wide array of the latest Nikon equipment. Bill even had his favorite new toy, a remote controlled quadcopter drone equipped with GPS, camera, and other frills.

Nikon Professional Services (NPS) is an organization designed for the sole purpose of providing support to full time professional photographers who earn their living using Nikon equipment. We were extremely fortunate to have Bill's NPS team visit the site. After almost 40 years as head of NPS, Bill will retire in January after the Consumer Electronics Show in Las Vegas. The team he brought to the 2926 site included NPS regional service representatives from the U.S., Canada, and Brazil. All the NPS team members are very highly qualified professional photographers in their own right.



*Brien Aho (Center, holding hardhat) briefs other members of NPS team. Brien, a retired U.S. Navy combat photographer, has photographed in 44 countries, and is published widely. He recently left an NPS position on the East Coast and moved his family to Austin Texas as the NPS Southwest Representative. He will support professional photographers in this area, and we can expect to see him again.*

From arrival at the site until past the lunch hour, the NPS team shot still photos and video of 2926. They did close-up shots of parts, tools, and various portions of the locomotive from every possible angle. They did tight shots, wide shots, inside shots, and shots from above with the quadcopter. (In the photo at right, a 2926 crew member working on wrapper sheet staybolts, hears the drone, but seems to be looking for it in the wrong direction as it approaches from behind for a close shot.)

A number of 2926 members were interviewed, some of them as they performed a specific task. We will not go into detail regarding the camera that was crunched while trying to get an underneath shot of our speeder moving down the track. Let's just say it wasn't a low cost incident.

Instead of stopping for lunch, the NPS crew opted to visit the AT&SF shops on South 2nd St. With Mike and Doyle as guides, they were off to the shops for one of the most interesting shop tours we have conducted. As with 2926, each of the NPS team members was looking for just the right shot, and of course, the massive shop buildings offer many targets.



(Continued on Page 2)

(Photo Shoot, Continued)

In a holiday greeting message, Brien Aho informed us that we will receive a video of their experience with 2926 and the AT&SF shops, but first is a very important project—Bill Pekala’s retirement ceremony. Mark Kettenhofen, who is editing the 2926 video, has been tasked with production of a going away video for Bill’s retirement. After 40 years on the job, that is important.

Mark lives in Evergreen Colorado. Like other NPS team members, he is an award winning photographer who has photographed all over the world. We are eagerly looking forward to his final product. The 2926 restoration team appreciates the interest shown by Bill and his NPS crew. We also look forward to having Mark, Brien, Bill and any other members of the NPS team drop by any time. Before long, with 2926 under steam again, we will provide some real action for them.



*Herding Cats? Trying to get the 2926 work crew together for a group shot with the locomotive is not easy. One NPS team member shoots from atop Lurch to record the process as crew members mill around.*



*In the AT&SF Shop’s main assembly building, Bill Pekala flies his camera equipped quadcopter drone (upper right corner) to get a video clip of his NPS crew.*

## A COVER FOR 2926: SHELTERING AN INVESTMENT

**AT&SF 2926 Is Now Worth Far More Than The One Dollar NMSLRHS Paid For It In 1999. Fifteen Years, Extensive Material And Monetary Support, And Tens Of Thousands Hours Volunteer Labor, Have Transformed The Rusting Relic Into A Valuable Icon Of New Mexico Rail History. It Now Needs Shelter.**

Pictures of 2926 taken since last September show a tarpaulin covering the locomotive’s cab. There is a very good reason for the cover. The interior woodwork of the cab has been restored and painted. It looks great and needs protection from the elements. As completion of the restoration nears, the entire locomotive will need protection from weather and vandalism—both of which contributed to the locomotive’s deterioration during its 46 years on Albuquerque’s Coronado Park.

Covering the entire 121 feet of the locomotive and its tender with tarpaulin might not be impossible, but it would certainly would not be convenient, nor would it provide protection from vandalism such as we experienced in August 2012.

A home for 2926 has been on the minds of the Society members since it was acquired from the City of Albuquerque. We were always aware that once restored, sitting in the open was not an option. Though our members have experienced cold, heat, wind, dust and other harsh conditions, the restoration has proceeded. And we are very appreciative of the generosity of the BIA and GSA for providing the space.

Now, nearing completion of the restoration, and with a permanent home not yet available, 2926 must have a shelter. That shelter is in the planning stages, and within the next few months, 2926 will have cover. Since space is limited, the shelter facility will be too small to provide for inside work, but at least 2926 will have protection from weather and vandalism. Planning for a permanent home will continue.

The planned shelter is the result of our good fortune in having strong dedicated supporters. One, the U.S. Bureau Of Indian Affairs, has been very supportive since the agency allowed us to move into the current site in 2002. The other is a rail fan who has followed and contributed to our progress for several years. Though preferring to remain anonymous, that supporter stepped up at just the right time with a \$100,000 donation earmarked for 2926 shelter.

The result of that support will soon appear from just inside the 8th St. entrance to the pit on the current work site. The track from our work pit inside the GSA gate to 8th St. will be rebuilt, and a prefab metal building will be placed astride the track just inside the 8th St gate. The building will be long enough to store the locomotive and tender. Workplace inside will be limited, but for work sessions, they can be moved westward to the pit and current work space.

Don MacCormack, Frank Gerstle, Randy McEntire, and others have completed the design for the work, and Requests for Proposal have had a response from 5 contractors.

Look for an update in the next NMSLRHS newsletter.



*The Nikon quadcopter hovering above cannot get pictures of the restored 2926 cab. The tarpaulin covering the cab was put there for protection for the elements.*

# 2013 TASKS IN PICTURES

The origin of the statement, "One picture is worth a thousand words." is uncertain. Whether it was Brisbane in 1911, Bernard ten years later, an ancient in China or Japan centuries ago, or even Napoleon as some insist, most would agree that it is true. So let us use images to highlight some of our 2013 tasks. We can't cover all tasks here, but here is a pictorial of some.

Many more photos, along with video clips can be found on the NMSLRHS web site at: [www.nmslrhs.org](http://www.nmslrhs.org).

## Those Pesky Staybolts

Restoration (repair or replacement) of the hundreds of staybolt assemblies probably caused more discussion, and certainly more unprintable commentary, than any other single task in 2013. All staybolt assemblies had to be checked, cleaned, and evaluated for repair or replacement. Many sleeves and caps, (and even a few bolts) required replacement.

At virtually all work sessions, whether hot, cold, or windy, some of the crew could be found removing staybolt caps, and cleaning, scraping, and brushing, the components of each staybolt assembly. Decisions were made regarding reuse or replacement. All reusable parts required cleaning and refurbishing. The removal and cleaning was all manual labor with lots of dirt and grime. Fortunately, a number of our volunteers seem to be very qualified for that type of grunt work.

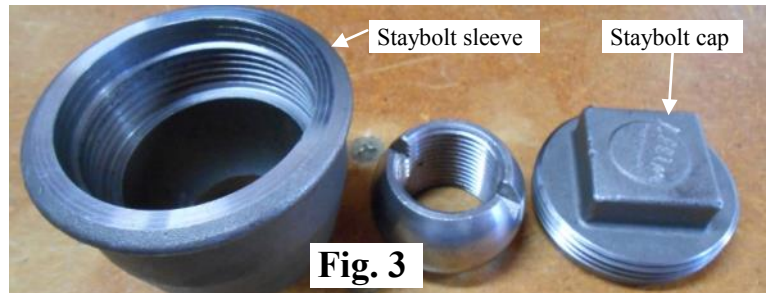
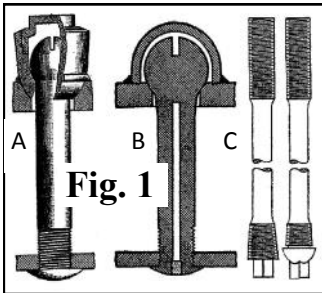

*Staybolt assemblies vary. Parts of some staybolt assemblies and deterioration examples are shown above. Fig. 1 shows three types. The first (A) shows a three piece assembly with the bolt head seated in a removable sleeve with a threaded cap. In a two piece type, (B) the seat is permanently fixed on the boiler wall. Two types of crown sheet staybolts are shown in (C). In Fig. 2, at least three (and maybe all four) of these staybolt assemblies will require some parts replacement. Variations go beyond just length or fixed versus flexible. There are also different sizes of sleeves and caps. Fig. 3 shows some of the replacement parts.*



***ALL** staybolt assemblies must be cleaned, inspected and have a new copper sealing washer installed. Those components that are deteriorated beyond reuse must be replaced. Parts that are to be reused are cleaned and held for reassembly.*

*Fig. 4: A typical corroded staybolt assembly with cap removed, looks like it may only need cleaning and a new washer. Fig. 5-9: The old washer is removed. Using a wire brush, the corrosion is removed with a cloud of rust. To prevent more corrosion while waiting for the new copper gaskets to be acquired and shaped, 30 - weight oil is squirted into the sleeve and a clean cap is installed.*

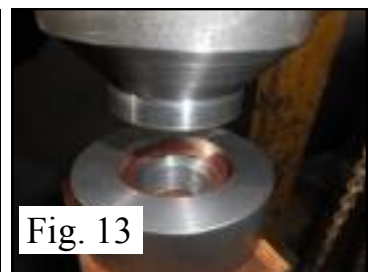
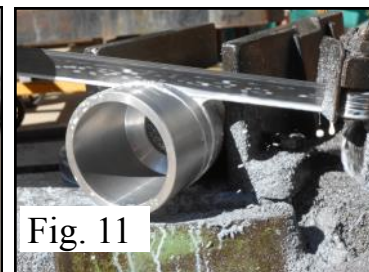

*Fig. 10-11: George Trever is caught sitting down on the job, but he has a good reason. He is operating the metal saw to prepare staybolt sleeves. Though many of the staybolt components were purchased from suppliers in other parts of the country, there was much cutting, fitting and shaping work to be done on site. Fig. 12-13: In several instances, 2926 crew members had to come up with innovative solutions. In this case, flat copper washers were purchased and a tool was made to reshape them.*

(See More 2013 Task Info On Page 6)

# BANGING ON A 2900

FEATURING—THE 2926 PIT RATS

And

The Franklin Automatic Compensator

By MIKE HARTSHORNE



It has been a year since Dr. Mike Hartshorne produced one of his “Banging on a 2900” articles. The following one is not about just one individual 2926 crew member. It addresses the “Pit Rats” - - - members assigned work in the pit under the locomotive where everything is dirty and greasy. The space is cramped, and removing heavy parts from overhead is normal work.

To really understand and appreciate Mike’s narrative of the Pit Rats’ job, one must be aware of the following situational facts.

1. This locomotive will be 70 years old in May. Its maintenance infrastructure disappeared years ago. The Pit Rats, and all other crew members must often develop their own tools and equipment.
2. Though the Society is populated with many highly educated and technologically experienced individuals, it is obvious that none of them have hands-on maintenance experience with the massive 70 year old machine—they must learn as they go.
3. All 2926 crew members must learn from the various reference materials the Society has acquired, the few old timers that can be located, and a very small number of other folks who have restored similar equipment.
4. Add to the above points the fact that 2926, sans tender, is more than half a million pounds composed of thousands of parts, all heavy and many rusted in place, and all work is being done outside in whatever weather occurs.

This “Banging on a 2900” deals with the critical issue of drive wheel alignment. Anyone familiar with wheeled vehicles is aware that alignment between the frame of the vehicle and the wheels upon which it rides is critical. If the wheels of an automobile are out of alignment, tire wear will increase, the vehicle will tend to ‘wander’, and it might be difficult to steer in a straight line.

If the wheels of a locomotive are out of alignment, wear is also a problem. With no steering capability, there is a serious alignment issue. Misalignment could lead to overheating of wheel bearings or even derailment--and a serious train wreck. When a steam locomotive’s axles are at right angles to the frame, the locomotive is said to be ‘in tram’ and the wheels are properly aligned. To deal with track curvature, suspension movement, and other actions, the axles must be allowed some vertical and lateral movement. To allow the movement and stay aligned, a system of ‘shoes and wedges’ is employed on both ends of each axle to absorb wear and maintain alignment. (NOTE: Because they absorb wear, shoes are also called wearplates.) The shoes and wedges are inserted in the frame pedestal between the pedestal jaws and the ‘driving boxes’ that carry each end of the axle.

Wearplates fore and aft of the drive box and a wedge between the rear pedestal jaw the wear plate position the drive box in the frame. On older locomotives as wearplates wear, the wedges must be adjusted from time to time to compensate for thinning of the wear plate. Once the shoes and wedges are worn beyond adjustment, the locomotive must be shopped and worn or broken parts machined or replaced.

In the case of 2926, the manual adjustment is not required. The automatic compensator uses a big spring working against the wedge to negate the need for frequent adjustment bolt twisting. . . . Editor

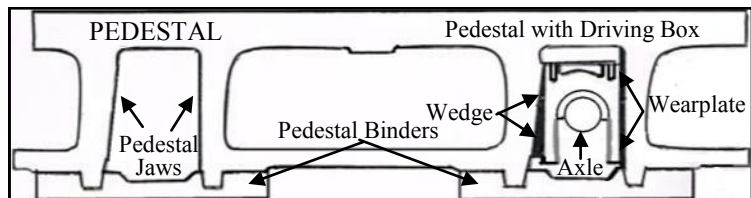

Sketch of a locomotive frame segment with two pedestals, one with a driving box. This shows an earlier non-automatic model with only one shoe

## The Franklin Railway Supply Company Automatic Compensator And The 2926 Pit Rats

By Mike Hartshorne

### ACT ONE

“What is this thing?”

“I don’t know but it has gotta come off.”

That was my introduction in the pit under the right side of the #4 driver box to the Franklin Railway Supply Company Automatic Compensator and Snubber for Drive Box. That is what our blue print sheet 199-29 called it. Since then I’ve nipped the end of one finger, mashed a couple of others, and gotten all 10 really grubby with 70 year old grease and dirt learning more about it. I was not alone. As a short platoon of 2926 pit rats struggled to remove, clean, inspect, lube and re-install **eight** of these assemblies they picked up several new names which cannot be printed in a family friendly news letter.

Pete found some diagrams of the device in his copy of Steam Locomotive Home Study Course, Volume 1 (1923). Pages 118-120 briefly discuss the mechanism for automatically adjusting the wedge plate in the rear of each drive box to compensate for vertical and to and fro wear in the drive box and pedestal jaws. The wedge is automatically adjusted to keep the driver axle perpendicular to the frame. The one diagramed is an earlier version of the Automatic Compensator. On the 2926 the automatic compensator is a little different with two wear plates, one on each side of the axle, but the principle is the same.

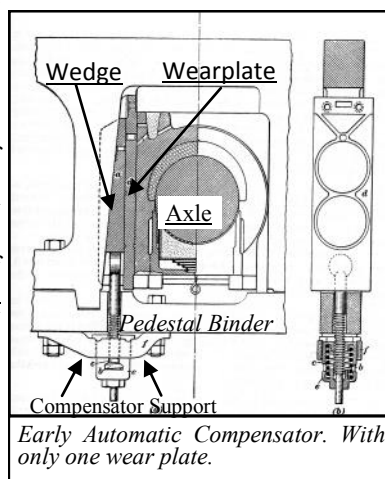

Early Automatic Compensator. With only one wear plate.

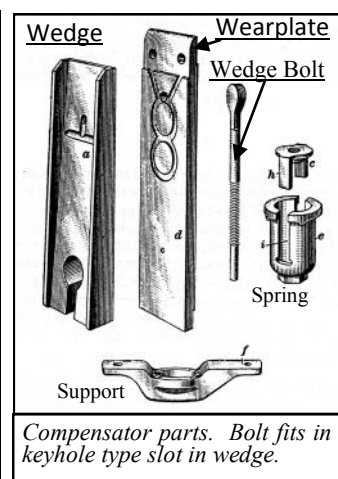

Compensator parts. Bolt fits in keyhole type slot in wedge.

(Franklin Continued)

Did I mention that the Franklin Automatic Compensator is **HEAVY** and hangs overhead in the pit from bolts and studs in the pedestal binder under the drive box with nut sizes ranging up to 2 3/16 inches with little room to swing a wrench? The pit rats were nervous about the first one because somebody knew there was a **BIG** spring inside and it wasn't clear if it was going to 'sprong' when the last nut came off. It didn't. With remarkably tenacious crud the whole assembly was glued into one piece. After serious work with wire wheels, scrapers, and the parts washer, actual metal was liberated for inspection. It was a serious day's work to get it greased up and back on before the sun went down. (See picture series A-F below)



A: Lowering compensator support. In the pit working next to the drive wheel.

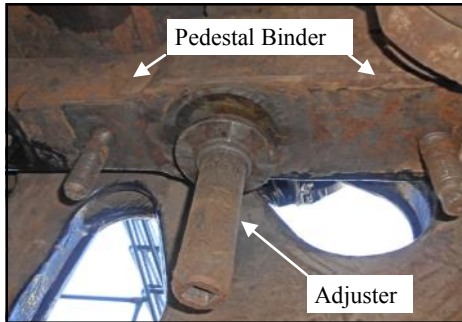

B. The pedestal binder after the automatic compensatory body and springs are removed. Note square drive, mushroom head adjuster is still in place on the threaded wedge bolt.



C. Removed compensator support, spring follower and springs still cemented together with historic dirt and grease.

The tenacious pit rats got better at the job with practice. Each subsequent winter work session saw one or two gotten off, cleaned up and back on. As hard as it was to unwind the nuts holding the automatic compensators on it was even harder if they got in a bind on the way down. Just when victory was in sight the project hit a snag. The wedge bolt on the left side #1 drive box was found broken off even with the pedestal binder. Who knows how long it had been that way. All the others were intact.



D. All cleaned up and ready for re-install.



E. Bottom of the body of the automatic compensator.



F. It takes several pairs of hands to get it back in place.

It looked like we'd need to pull the pedestal binder down from the box. It looked simple. Unbolt it and it should "drop right off" onto the jack on a pile of cribbing. As 2013 gave way to 2014 all the nasty nuts were loose but the pedestal binder would not budge before sundown. The project stopped. The studious pit rats had to learn more about drive boxes the old fashioned way.

### HISTORIC INTERLUDE

In the meantime a little research established that the Franklin Railway Supply Company had been incorporated in 1917. The company made a variety of items such as pumps, lubrication systems for drive boxes, automatic (air operated) firebox doors (Picture G) and steam powered grate shakers for coal fired locomotives, radial buffers (such as the one being built to replace the one stolen from 2926), power reverse gear, and of course the Automatic Adjustable Driving Box Wedge as touted in the Frisco Employees Magazine July of 1931. Later the company made aircraft wing panels from aluminum and morphed and merged with other companies until it finally became Macrodyne Industries in 1974 totally unrecognizable as a railway supply company.

### ACT TWO

The next two work sessions put the snarling pit rats back underneath the first driver with renewed determination to get the pedestal binder down. Dave mentioned that steel is about 500 lbs per cubic foot. There is a lot more than a cubic foot in a pedestal binder. **REAL D\*\*\* HEAVY** is the phrase I heard. The little transmission jack was ditched in favor of a couple of bottle jacks and serious loops of chain passed over the frame and underneath the pedestal binder for stability.



G. Franklin air operated automatic firebox doors.

(Continued on Page 6)

(Franklin, Continued)

With nuts backed down about 1/2 inch the pedestal binder was heated by Ron on one end and Danny on the other. As the ends of the pedestal binder got to about 500 degrees Fahrenheit, Scott placed a 30 ton pancake hydraulic ram on top of the binder and started pushing. (Pictures I, J) **BLAM!** Down it came that magic 1/2 inch just as the rest of the crew returned from lunch.

After that it was a tedious process of jacking, cribbing, re-rigging chains and slowly getting the very heavy pedestal binder down safely. With the binder coming down, the wedge and its adjacent wear plate began to slip down breaking the bonds of really old grease and grit. Getting the wear plate down was relatively easy but the wedge only dropped a few inches and stopped.

After some interesting theories were tried it was discovered that the wedge was suspended from the lubrication lines, (Picture K). Our 1923 wedge diagrams did not show the modern lubrication system on the 1944-built 2926. When the lines were removed gravity was once again our friend and enemy as the wedge was coaxed down, then rearwards, and finally slipped out on a wood bridge over the rail behind its driver.



I: Heating pedestal binder bolt as seen through drive wheel.

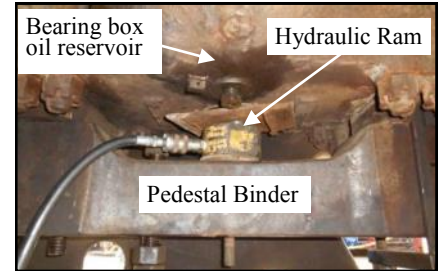

J: Ram placed between bottom of bearing box housing and pedestal binder.



K: The 2926 "modern" lubrication lines attached to the top of the wedges provided a learning opportunity for the pit rats.



L: Wear Plate (top) and wedge (bottom) show lubrication grooves and little wear. Gap on right end of wedge is slot for wedge bolt head.

After that exercise cleaning up the wedge and wear plate for inspection was anticlimactic. The wear plate at installation, is higher than the wedge. It drops as it wears, its position related to the wedge determines need for replacement. The top of the wear plate was found to be 3 inches above the wedge top, indicating that there was very minimal wear on the plate, and the wedge was in fine shape, (Picture L).

The broken wedge bolt (Picture M), will need a little fixing. Using some available threaded rod, we know just the guy to do it. The victorious pit rats expect a lot more heavy learning about drive boxes as the 2926 restoration continues.

**Note:** So far no actual pit rats were seriously damaged during this production. But they will be much more well versed in the design and operation of the 'latest model' (circa 1944) Franklin Automatic Compensator on AT&SF 2926.

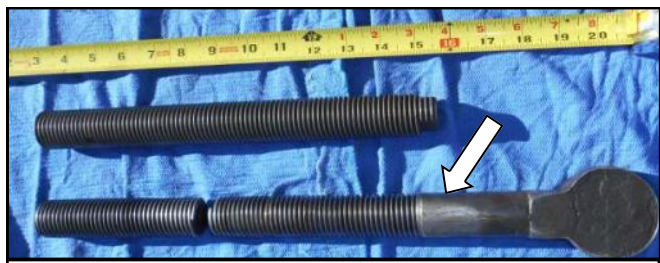

M: Broken wedge bolt is cut at arrow. A 13 inch section of threaded rod is welded and trued up for use. Just another day in the life of the folks banging on a 2900.

## MEMBERSHIP AND SAFETY REMINDER

With the holidays long past, it is time to remind members that it is now a new year. That means membership renewal and safety refresher training. For those members who hold annual membership, and have not yet renewed, please renew at your earliest convenience. Active membership and current safety status are necessary to work on the 2926 site.

For those who have renewed their membership and were not able to attend the first refresher session, Safety officer John Spargo states that he will conduct one more safety refresher at the restoration site on Saturday Feb. 15. Any members who have had safety training, and miss the refresher training will be required to take the regular safety training at a future new member training.

# A FEW MORE 2013 TASKS IN PICTURES

Staybolt work wasn't the only task in 2013. It just seemed that way at times. Here are some photos of other important task activity during year just ended. Some of the pictures feature a few of the tough, dedicated volunteers who show up on the 2926 site every work day regardless of the weather.

## INNER SPACE

**Fig. 1: Space travelers?**

*Yep, inner space. Anthony and John are all dressed up for a trip inside the 2926 boiler for an internal washdown.*

**Fig. 2: Connecting to a convenient fire plug, the two intrepid travelers take a high pressure hose inside the boiler.**

*The high pressure wash is used to scour the inside walls of the boiler removing scale and accumulated sand.*

*There is another very important step to be done before the flue tubes and superheater tubes can be installed. That is the application of a protective coating to the inner walls—an improved coating that did not exist when the locomotive was built.*



## TIGHT SPACE

**Fig. 3: There are more cramped spaces than inside the boiler. In Fig. 3, Martin is under the combustion chamber. What he is working on? Saybolt caps, of course.**

**Fig. 4: Here, looking through a drive wheel, Martin's head is barely visible at right center. At left center, the end of the locomotive's huge leaf spring can be seen.**

*Crawling into such spaces was unnecessary when 2926 was active. In the shops, the boiler was lifted from the frame by a huge crane.*

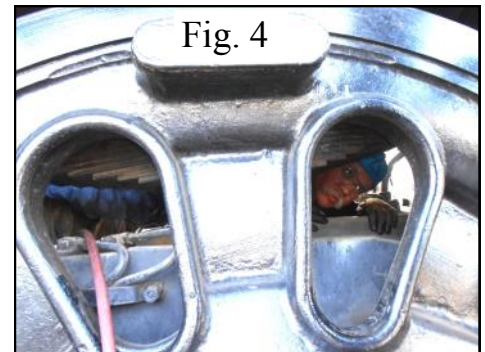

## AMPLE SPACE AND SMALL TASKS

This newsletter has only scratched the surface on the number of tasks. The larger, complex tasks will have numbers of sub-tasks, and some require an entire team of crew members. However, there a lot of tasks dealing with parts, appliances, and components that can be removed to a workbench where there is plenty of space. Such tasks often become the job of one individual. That is the case in the photos below. Though several members have spent time with the 2926 electrical parts, ( Fig. 5-6) the individual components can be removed to a workbench for attention by one person.

There are other situations in which an individual becomes the 'owner' of a specific task, and spends many hours disassembling, cleaning, polishing, and reassembling one item. That is the case in Fig. 7 with Mike Swanson and a steam pump. Mike has spent considerable bench work time on such parts and equipment. The pump is actually not a part of the locomotive, but may be useful piece of support equipment when the locomotive is operational. It was among several items donated by 2926 supporter Jacob Schmidt of Wagon Mound, New Mexico.

Mike is a U.S. Navy Reservist and a long time NMSLRHS member who is on site almost every work session—well, except for the several months he spent in Kandahar, Afghanistan courtesy of the U.S. Navy.



This newsletter is published quarterly by the New Mexico Steam Locomotive & Railroad Historical Society, a New Mexico Non-Profit Corp.

President	Michael F. Hartshorne
Vice President	Bob DeGroft
Secretary	Gail Kirby
Chief Mech. Officer	Rick Kirby
Chief Safety Officer	Jon Spargo
Newsletter Editor	Doyle Caton
Web Master	Rich Bugge
Community Liaison	Steve Bradford
Fundraising	Ed Kibel

#### MAIL ADDRESS

NMSLRHS  
P. O. BOX 27270  
Albuquerque, NM 87125-7270  
Tel: (505) 246-2926 **Web:** [www.nmslrhs.org](http://www.nmslrhs.org)

## SPONSOR A SUPERHEATER

### Flue Tube And Brake Shoe Sponsorships Have Sold Out

Financial support derived from sponsorship of specific 2926 components has been crucial to purchase of parts, materials, and services. Now there are no more flue tubes or brake shoes to sponsor.

There are still folks wanting to sponsor a piece of the restoration. And we still need financial help to get 2926 under steam.

So what do we have left to sponsor?

Among the few large items still available for sponsorship are the superheater tubes. They are among the very last components that will be installed. That is **after** installation of the flue tubes—and even closer to having 2926 ready to run.

When flue installation starts, the clock on the 15 year countdown until the next flue replacement also starts. That puts a bit of urgency on the need to be fully prepared to move quickly to insertion of the superheater tubes.

Sponsorship of the superheater tubes is set up in the same manner as the flue tubes. To sponsor one or more superheater tubes, or for detailed information relating to the number of superheater tubes available, sponsorship cost, etc, please check out our web site at [www.nmslrhs.org](http://www.nmslrhs.org), or call us at 505 246-2926.

\* \* \* \*

#### FLUE TUBES & SUPERHEATER TUBES

The picture of a flue sheet below represents the number of the tubes in the 2926 boiler. They all have sponsors.

The superheater tubes are inserted into the large flue tubes **after** the flue tubes are reinstalled. Though some superheater tubes already have sponsors, there is still an opportunity to sponsor one or more.

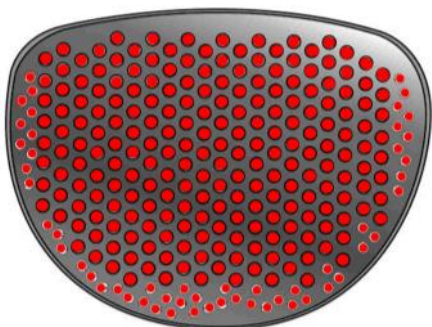

## SANTA FE 2926 DISPLAY



*NMSLRHS display in the lobby of the New Mexico State Land Office. The display occupies both sides of the panel directly in front of the Land Commissioner's Office.*

The end of 2013, and start of 2014 brought an interesting opportunity to NMSLRHS and the WHEELS Museum. It was an invitation by the State Land Commissioner to place a rail heritage display in the lobby of the New Mexico State Land Office. It required some quick action to put together the materials, and set up the display, but it will be available for future events.

Only a couple of blocks from the New Mexico State Capitol, the display will be available to a wide audience throughout January. With the New Mexico Legislature in session, a reception for Legislators and other officials will be held at the display on the afternoon of January 28.

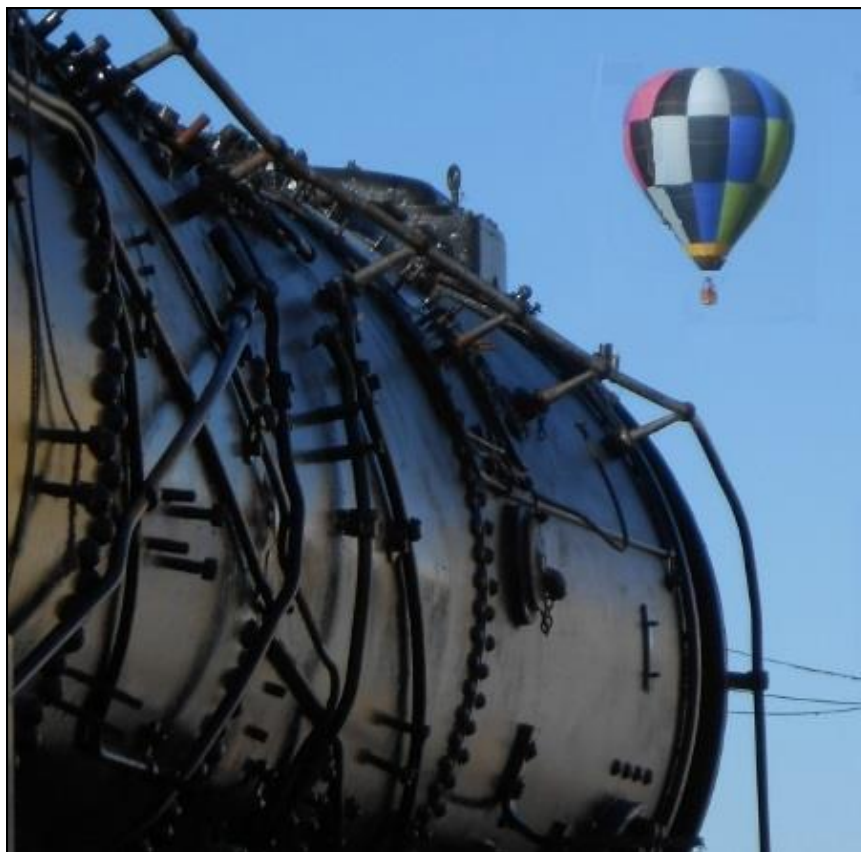

*Quadcopter drones are not the only way to get a good vertical view of the 2926 restoration site. This photo is included for our founder, Ed Bukove, a former hot air balloonist who now resides in Illinois.*